

REV	DESCRIPTION	DATE
A/0	Initial issue	2017-05-09

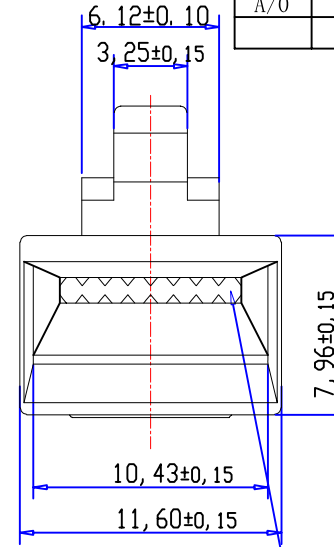

ø1.0线孔。

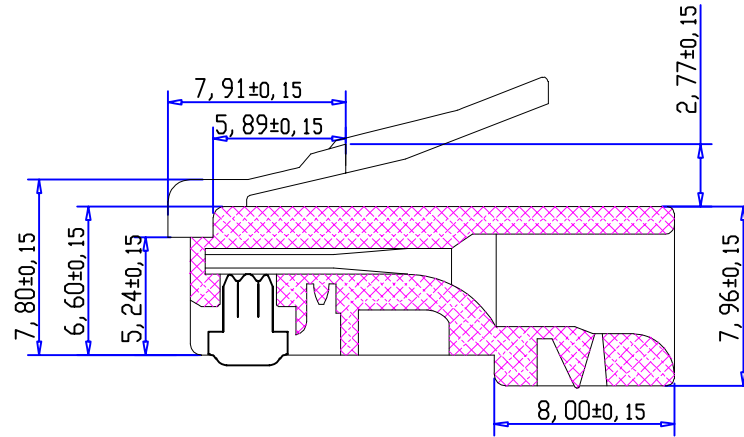
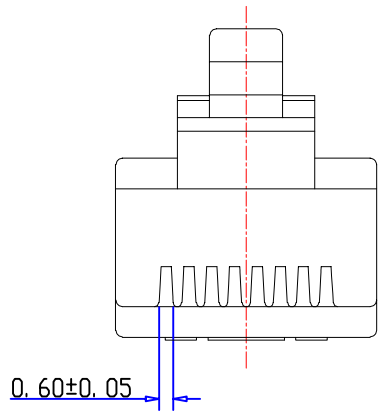
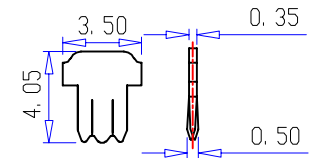
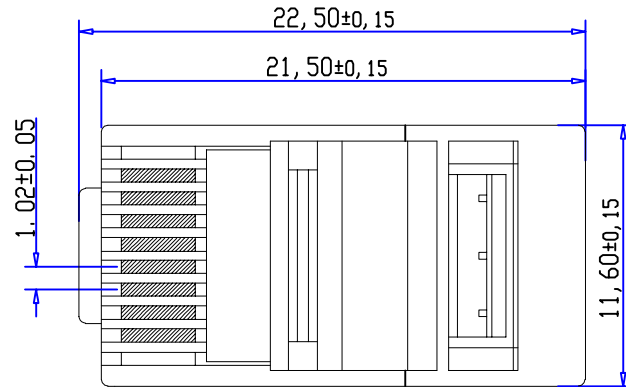

For Standard Wire

FEATURES:

1 Electrical Test:

- A. 250V AC max at 2 amps.
- B. Dielectric with standing 500volts AC.
- C. Insulation Resistance:500 megaohms.
- D. Termination Resistance:35megaohms.

2 Mechanical:

- A. Cable-to-Plug tensile strength-20LBs (89N)min.
- B. Durability:500 mating cycles.



ITEM	CAT5E PLUG UTP	CUSTOMER		UNITS	mm	PAGE: 1 of 1
PART NO.	VC-F17-0002	CUSTOMER NO.		SCALE		
PRODUCT NO.	NM005	REV:	A/0	DATE	2017-05-09	
APPROVED BY:		CHECKED BY:		DRAWN BY:	CT	